

CrossTalk™ Mediation Products

Femtocell-Core Network Access Point TeMIP Access Modules

- ◆ Fully integrated TeMIP fault management of Alcatel Lucent components supporting Femtocell access to Core Networks
- ◆ WMS Access Module providing Fault Management for BSR Signalling Gateway (BSG) and IP-ATM Protocol Converter (IPC) equipment
- ◆ ALSMS Access Module providing Fault Management for ALU Security Management Server for Brick (VPN Firewall Security Gateway for BSR Femto solution)
- ◆ Functionally rich; including powerful entity modelling and mapping, alarm resynchronization, and inter-system connection monitoring
- ◆ Alarm status synchronisation between Femtocell platforms and TeMIP

OVERVIEW

Two CrossTalk™ Mediation Services Access Modules (AMs) provide fault management for the following Femto Access Components

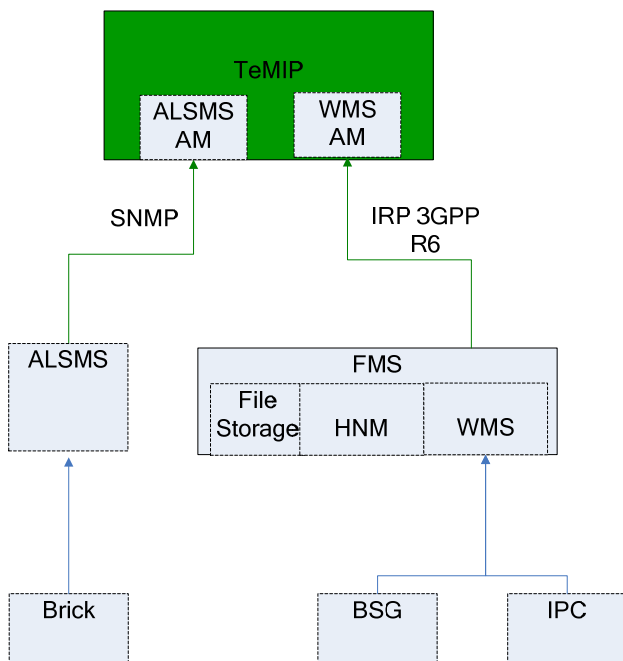

The WMS AM alarm management interface supports IRP 3GPP R6. The ALSMS AM alarm management interface is SNMP. Both AMs provide configurable mapping of events to TeMIP OSI alarms and clear correlation of these events. The AMs automate full resynchronisation between the WMS and ALSMS platforms in the event of re-establishment of connectivity (WMS) or ICMP reachability (ALSMS).

Equipment Modelling

The WMS AM provides a rich and granular sub-class model for BSG and IPC entities. Only Global Class instances for these entities are required to be dataloaded; sub-class entities are not instantiated in TeMIP. ALSMS supports Brick and Object (for SUN platform traps) sub-class entities.

Configurable Mapping Rules

Mapping of WMS and ALSMS notifications to TeMIP alarms is highly configurable using the CrossTalk™ Mapper engine. Rules to translate notifications into HP OpenView TeMIP events can be modified and dynamically reloaded. This capability drastically reduces platform upgrade costs.

Alarm Resynchronisation

Full resynchronisation between TeMIP and WMS/ALSMS is supported. This ensures recovery (manual or automatic) in the event of communications loss or system re-connection. Manual resynchronisation can be requested for WMS/ALSMS managed elements.

Alarm De-Duplication

Full Alarm de-duplication monitoring enables the liaison to guarantee operation context integrity. Full support for operation context resynchronisation using the TeMIP Resynchronisation FM is provided.

Architecture

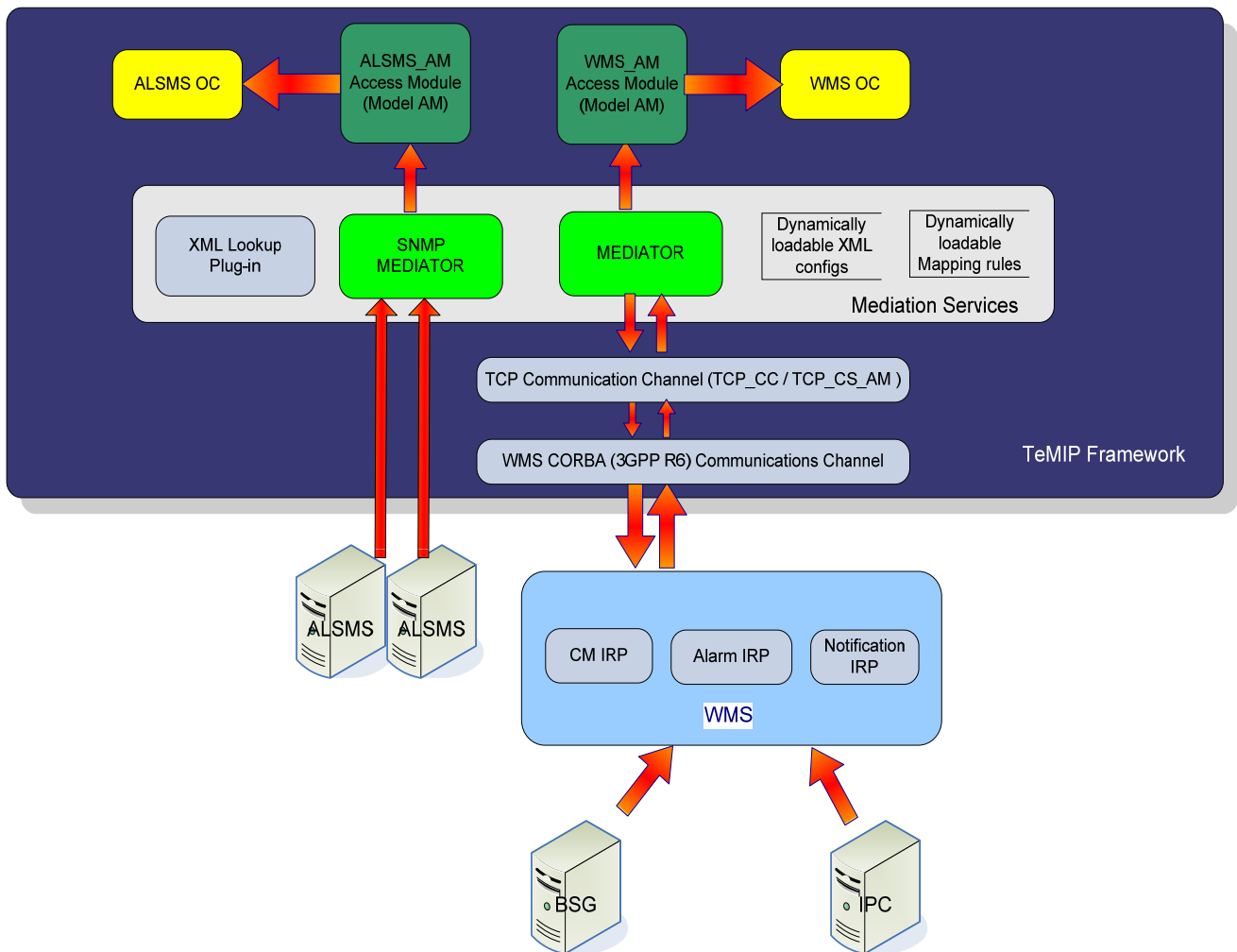

Key Features:

- ◆ Reception of "real time" alarms from WMS and ALSMS platforms
- ◆ Configurable alarm mapping and modelling in TeMIP
- ◆ Automatic and manual alarm resynchronisation
- ◆ Clear correlation and alarm de-duplication
- ◆ AMs support OC resynchronisation via TeMIP Resynchronisation FM
- ◆ Detailed object model for BSG and IPC entities
- ◆ Heartbeat monitoring (WMS) and ICMP polling (ALSMS)
- ◆ Support for ALSMS Sun Platform Traps
- ◆ Tagging of non-clearing ALSMS alarms

Systems Mechanics Ltd

Ferndale Court, West End Road, Mortimer, Reading, RG7 3SY
 Tel: +44 (0)118 9332220
 Fax: +44 (0)118 9333807
 Email: sales@sysmech.co.uk

CrossTalk™, SysMech™ and their respective logos are trademarks of Systems Mechanics Ltd. All other trademarks are the property of their respective holders. Information in this document is subject to change without notice. Copyright © 2011 Systems Mechanics Ltd. All rights reserved.

Registered Office: The New Barn, Mill Lane, Eastry, Sandwich, Kent, CT13 OJW, UK. Registered in England number 3030744 · V.A.T. no.: 661 7041 49